



DUTCH RECOVERY SYSTEM

Dutch Recovery System B.V.
Morseweg 7
4104 BL Culemborg
Netherlands
+316 424 062 99

INNOVATIVE DAMAGE-FREE TOWING AND RECOVERY SYSTEM

Table of contents

SAFETY	4
TIME SAVING	5
INSTRUCTION	6
APPLICATION	7
BASIC SETS	8
ACCESSORIES BASIC SETS	9
SETS	10
SETS	11
ADAPTER PINS	14
OVERVIEW	17
TOWING	20
LIFTING/HOISTING	22
ACCESSORIES	24
OVERVIEW	26
STORAGE	27

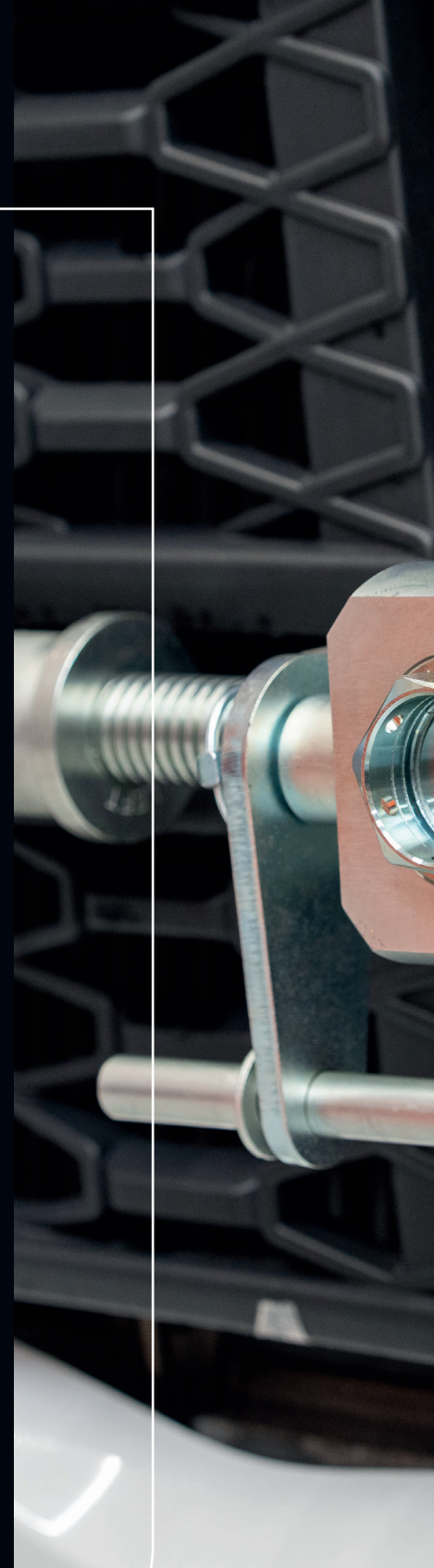



More than pieces of metal: the team behind Dutch Recovery System

At Dutch Recovery System, it is about more than just parts; we deliver reliability. Meet the specialists who ensure this every day:

- **Design & Production:** Jasper and Laurens form the technical heart of DRS. They design, test, and build all our components entirely in-house. Every part is specifically developed to perform effortlessly under the most extreme conditions in the recovery industry.
- **Inspection & Support:** Ruud ensures that your equipment remains safe and in top condition. With our mobile service van, he comes to you for on-site inspections, direct tailored advice, and live product demonstrations.

Together, Jasper, Laurens, and Ruud build your reliability. This is how we minimize downtime, optimize your workflow, and get the most out of your equipment.

INNOVATION. QUALITY. DUTCH RECOVERY SYSTEM.



SAFETY

Vision and innovation

The Dutch Recovery System (DRS) continuously innovates to make truck recovery easier. Our focus is on safety, efficiency, and speed. Therefore, targeted training and an annual inspection of DRS components are an integral part of our vision.



TIME SAVING

Efficient recovery without damage

The primary goal of the DRS? To provide recovery operators with safe tools for a flawless operation. With our system, a stranded truck with a technical breakdown can almost always be towed quickly and safely. This saves time and prevents traffic jams. Because incorrect recovery methods can lead to costly damage, manufacturers are also paying increasing attention to proper lifting and towing techniques. Consequently, they are increasingly recommending the use of the DRS, as it prevents damage to bumpers or radiators when hitting speed bumps and potholes. The system has been extensively tested throughout Europe and has proven itself as the ultimate damage-free, innovative solution.



Smart technology, lower axle load

Thanks to the DRS, you lift vehicles precisely from the recovery points designated by the manufacturer. This moves the lifting point forward and relieves the T-beam of the recovery vehicle. Because the body arm can be fully retracted during towing, weight transfer is significantly reduced. This allows you to easily stay within the legal rear axle weight limits and prevent excessive wear.

INSTRUCTION

- The T-beam of your recovery system must always be in a horizontal position during recovery.
- The coupling height varies by truck type. To be able to tow all compatible trucks, the recovery system (with a horizontal pivot point of the T-beam) must be height-adjustable between 0.5 and 1.2 meters. (If necessary, custom-made raised sliding beams can be manufactured.)
- Always visually inspect the truck's recovery points for cracks and fractures beforehand.
- Always clean threaded recovery points with a tap and lubricate them with Teflon oil.
- Screw in bolted components fully to the end of the thread, tight against the stop of the recovery point.
- Secure components with a bayonet connection firmly with the locking nut, ensuring the indicator line is in a horizontal position.
- Mount the traverse for both recovery and transport.
- Screw the DRS90-01 & DRS90-03 fully in to the end of the thread and then unscrew them one turn.
- When winching or hoisting, always use both components (DRS30-05/DRS90-01) in combination with a pulley.
- Always lock sliding bars connected to the DRS components with the corresponding locking pins.
- Avoid shock loading as much as possible.
- Never exceed the maximum values for the components specified by DRS B.V. Consult the manual for this.

Note: Be extra vigilant with vehicles with an increased risk of overloading, such as loaded trucks or trucks with a crane behind the cab. Recovering these vehicles is only permitted if the total load demonstrably remains within the prescribed limits.

Failure to follow the instructions of Dutch Recovery System B.V. may result in damage or bodily injury and is considered non-compliance with regulations. Remember that safe and proper use begins with common sense and caution.

APPLICATION

You can use the Dutch Recovery System in various ways, such as:

1. Winching with cables
2. Towing behind the recovery vehicle
3. Lifting and towing with a recovery vehicle
4. Hoisting/lifting with a crane
5. Towing with a tow bar

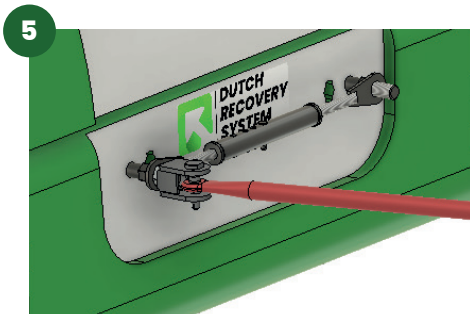
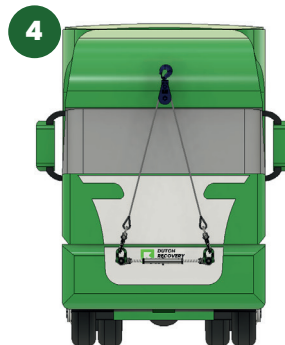
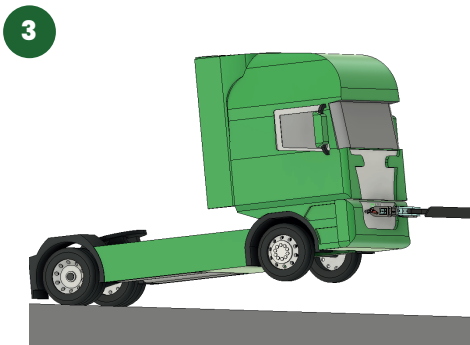
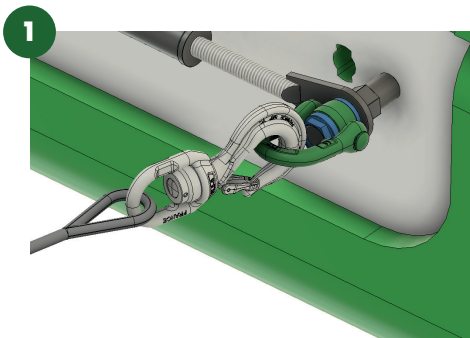

BASIC SETS

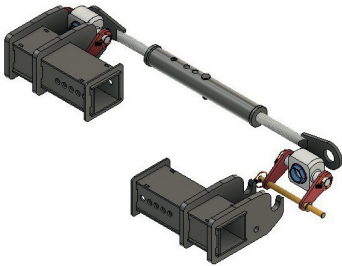

SET D1

TOWING SET DRS

DRS200-001

DRS Bracket

DRS30-01

Rotating Lifting Block

DRS40-01

Traverse Universal

€ 2 535,00



SET W1

WINCH SET DRS

DRS30-05

Rotating Winch Eyes

€ 930,00

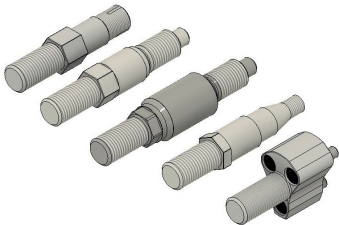

SET P1

PRESENT SET

DRS02-01

MB-Renault-MAN

DRS03-05

DAF 106 XF CF

DRS03-06

DAF XG XD

DRS05-03

Volvo FH FM >2013

DRS07-03

Scania S-series Next Gen

€ 3 170,00



SET T1

TOOL SET

DRS61-01

Wrench Holder

DRS61-55

Wrench -55

DRS61-74

Wrench -74

€ 215,00

BASIC SET

€ 6 850,00

ACCESSORIES BASIC SETS



ACCESSORIES

DRS07-05

TOWING SET DRS

Crank Hex 55mm

€ 15,00



ACCESSORIES

DRS75-124

DRS35-117-0150-26

WINCH SET

Saber Pro - 4M - 50.000 KG

Snatch Shackle 17 ton 150mm

€ 920,00



ACCESSORIES

DRS20-01

DRS20-02

DRS20-06

DRS20-07

PRESENT SET

TAP M45x3.0

TAP M48x5.0

TAP M30x3.5

TAP M20x2.5

€ 492,00

ACCESSORIES

€ 1427,00

BASIC SET + ACCESSORIES

€ 8277,00

SETS

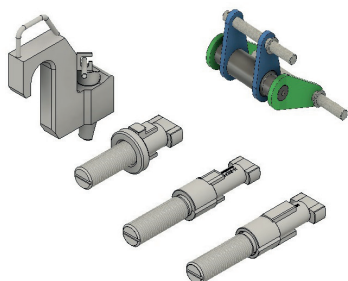

SET L1

LEGACY SET < 2016

DRS07-05

Scania 4 series

DRS05-02

Volvo FH-FM

DRS03-03

DAF XF < 2013

DRS03-02

DAF CF < 2013

DRS200-100

Bracket Adapter

€ 2 630,00



SET F1

FORD SET

DRS08-02-05

Ford F-max B

DRS08-03

Ford F-max A

€ 605,00

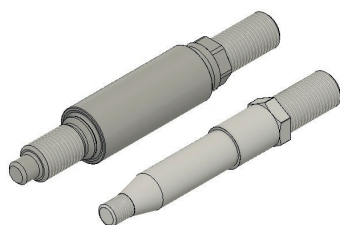

SET C1

CONSTRUCTION SET

DRS03-07

DAF XDC / XFC

DRS05-04

Volvo FMX

€ 1 340,00



SET T2

TOOL SET

DRS62-IN17

Allen socket 17 mm - 1/2"

DRS62-12

Cap for Tap 12 mm - 3/4"

DRS62-18

Cap for Tap 18 mm - 3/4"

DRS62-29

Cap for Tap 29 mm - 3/4"

€ 240,00



SET P2

DRS02-03

DRS05-05

PRESENT SET 2

MB ProCabin

Volvo Aero

€ 1 410,00



WORK SAFELY AND EFFICIENTLY WITH THE NEW DRS INSPECTION VAN ON LOCATION

At Dutch Recovery System, we build our Quick Towing System to the highest standards of durability and performance. To ensure your equipment continues to operate safely and efficiently year after year, we offer comprehensive annual safety inspections and certifications.

Regular inspections are not just about compliance; they are about safety and reliability.

Safety First: Recovery and towing involve heavy loads and high stress on the equipment. Annual checks guarantee that all critical components are in order, protecting your drivers and the public.

Prevent Downtime: By detecting wear early, you prevent unexpected breakdowns on the road. This keeps your trucks running and your business profitable.

Compliance and Legislation: In many regions, certified lifting and recovery equipment is mandatory. Our inspection ensures that your system meets the necessary safety standards.



Inspection On Location



Visual Inspection





Magnetic Particle Inspection

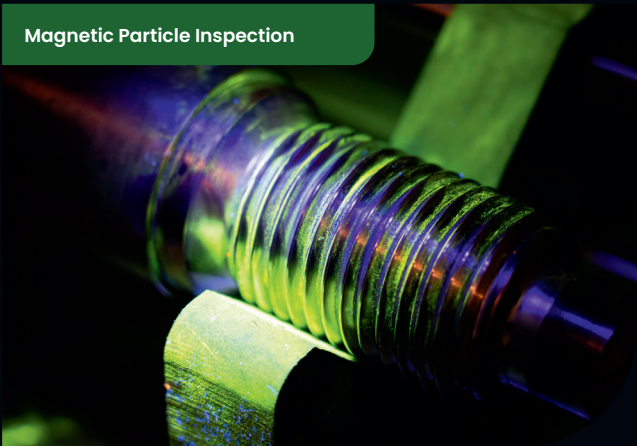

Expert Advice



ADAPTER PINS

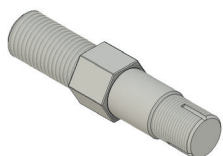

DRS02-01

Set MAN-MB-Renault

€ 440,00



DRS02-03

Set MB ProCabin

€ 680,00

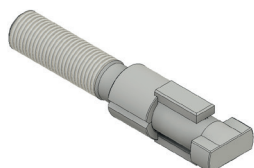

DRS03-02

Set DAF CF75/85 < 2013

€ 430,00

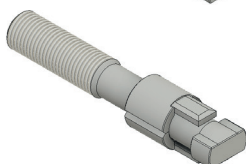

DRS03-03

Set DAF XF < 2013

€ 430,00

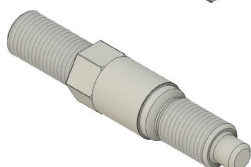

DRS03-05

Set DAF 106 XF, CF

€ 530,00



DRS03-06

Set DAF XG, XD

€ 640,00



DRS03-07

Set DAF XDC, XFC

€ 730,00

ADAPTER PINS

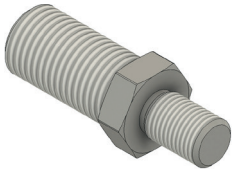

DRS04-01

Set van Hool-VDL pull pins

€ 390,00

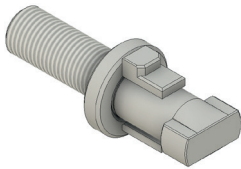

DRS05-02

Set VOLVO FH, FM

€ 470,00

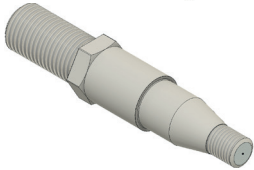

DRS05-03

Set VOLVO FH, FM > 2013

€ 530,00



DRS05-04

Set VOLVO FMX

€ 610,00

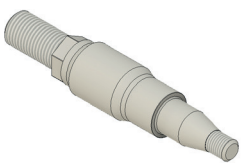

DRS05-05

Set VOLVO FH AERO

€ 730,00

ADAPTER PINS

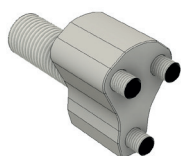

DRS07-03

Set S-Serie Scania Next Gen

€ 1030,00

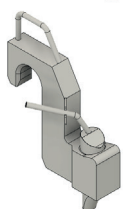

DRS07-05

Set Scania 4 Series

€ 880,00



DRS08-02

Ford F.Max B (Short Pin)

€ 265,00



DRS08-03

Ford F.Max A (Long Pin)

€ 340,00

OVERVIEW

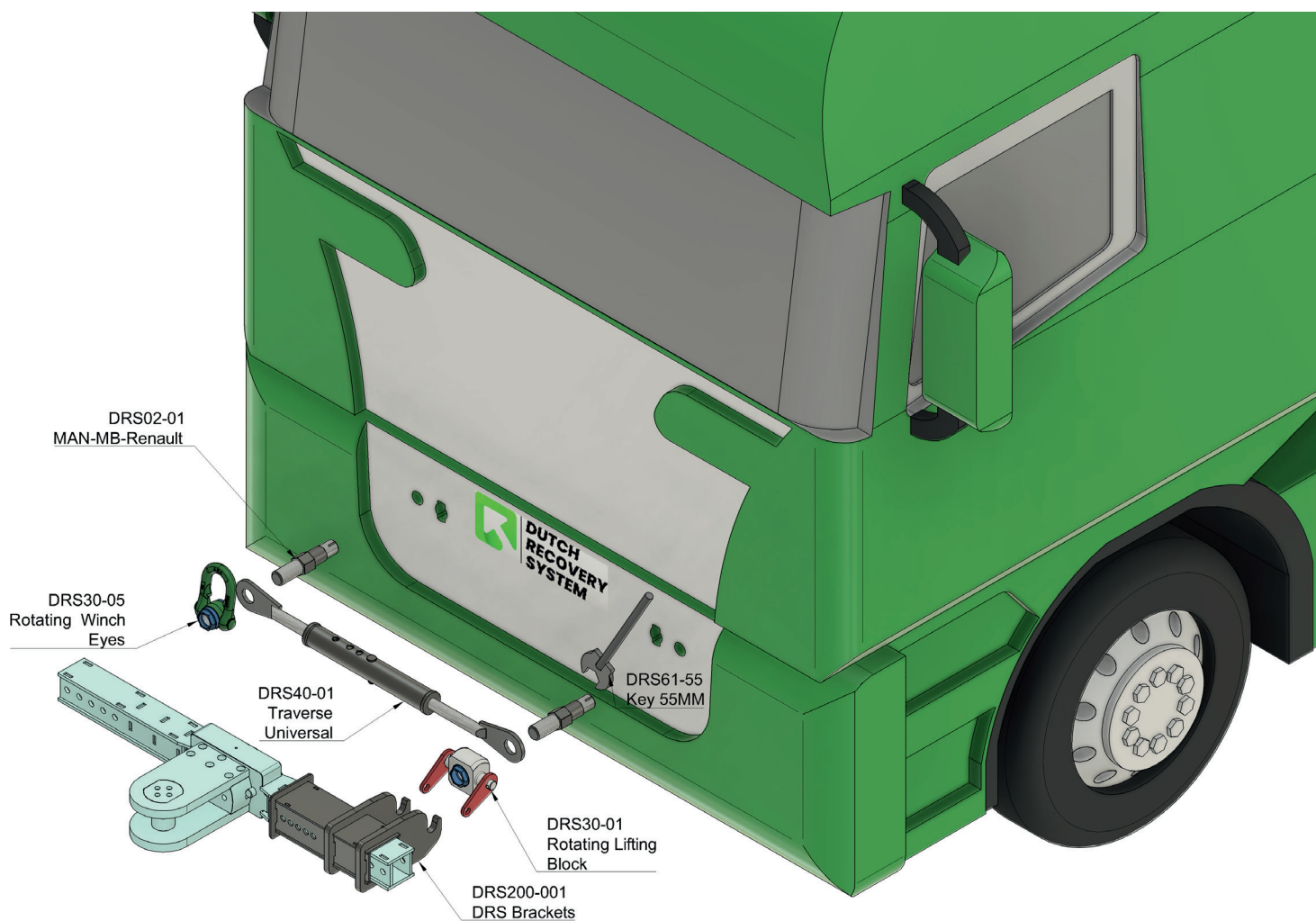

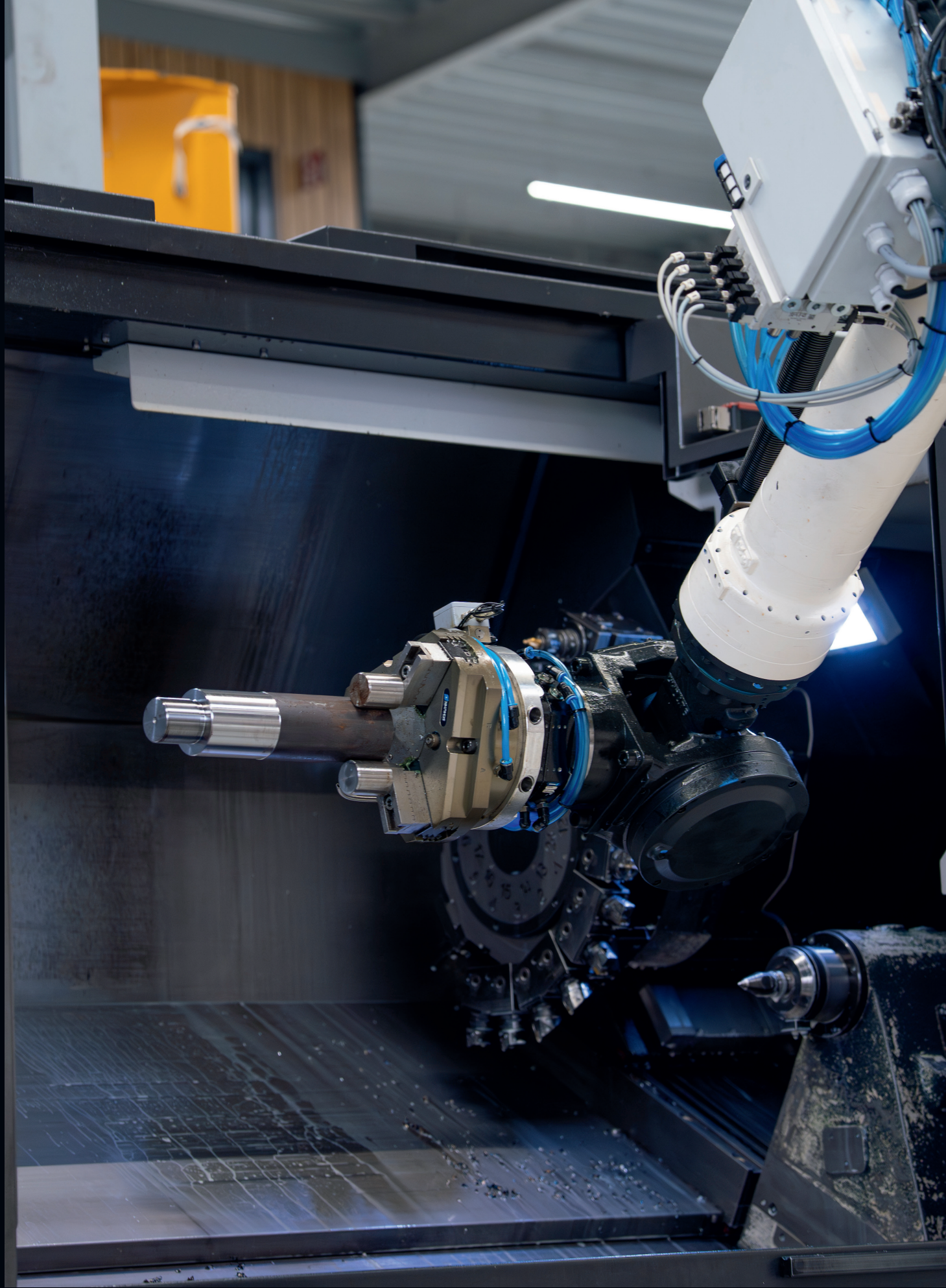

We built the system you rely on. Now we deliver it directly to you.

The story of Dutch Recovery System began in 2008, when Jasper Wijnschenk (founder of 3DTechDraw) and recovery legend Johan van der Zand joined forces. Johan had the practical experience and an idea on cardboard; Jasper and his team provided the high-quality engineering. It was the perfect synergy. For years, we were the exclusive, silent force behind the brand: we developed the prototypes, obtained the TÜV certifications, and produced the systems that became the European standard for damage-free recovery.

After Johan's retirement and the termination of the old sales partnership, the landscape changed. To continue improving the product, we had to bridge the gap between the factory floor and the customer. That is why we launched Dutch Recovery System in 2024 to deliver Factory Direct.

When you buy directly from us or our dealer network, you benefit from:

- **The Real Original:** You buy directly from the facility where the system was developed and built.
- **Continuous Innovation:** We do not copy old drawings, but continuously improve them. You get first access to upgrades in strength and weight reduction.
- **Direct Support:** No intermediaries. You receive support from engineers who know every tolerance and every weld seam.

We honor the past by building the standard. We secure the future by improving it.

TOWING

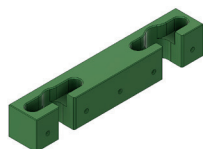
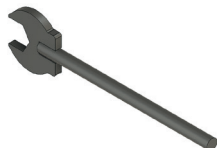
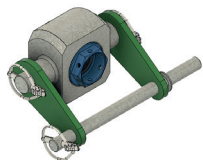

DRS30-01 Rotating Lifting Block Set

€ 800,00

DRS30-05 Set of Rotating Winch Eyes

€ 930,00

DRS40-01 Traverse Universal

€ 735,00

DRS61-55 Wrench 55

€ 80,00

DRS61-74 Wrench 74

€ 80,00

DRS61-01 Wrench Holder

€ 55,00

TOWING

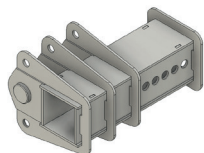

DRS100-001 Set of brackets for all brands

€ 1070,00



DRS100-002 Set of Raised Brackets for all brands

€ 1330,00

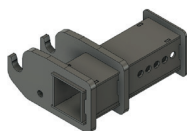

DRS200-001 DRS Bracket Set for all brands

€ 1000,00

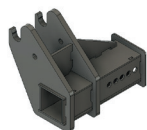

DRS220-001 Set of Raised DRS Brackets for all brands

€ 1260,00

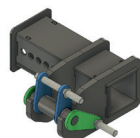
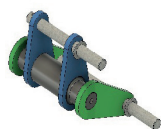

DRS200-100 DRS Standard Bracket Adapter Set

€ 420,00

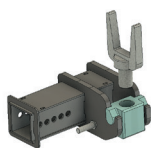
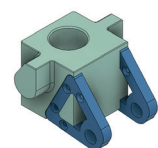

DRS200-110 Bracket Conversion Block 50

€ 620,00

Recovery vehicles come in many shapes and sizes. As a result, there are many different T-beam dimensions in circulation in practice. We keep the most common bracket sizes in stock as standard. In addition, we also supply custom-made brackets specifically for your vehicle at the rate mentioned above.

LIFTING/HOISTING



DRS70-11 Winch plate 100x10

€ 130,00

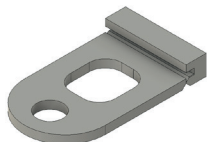

DRS70-12 Winch plate 200x10

€ 150,00

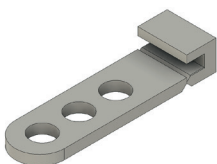

DRS70-21 Winch plate 100x20

€ 135,00

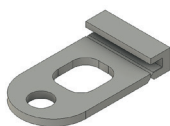

DRS70-22 Winch plate 200x20

€ 155,00



DRS75-001 Set of front axle chains

€ 150,00

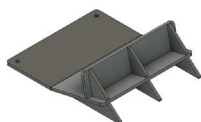

DRS72-001 Flip-Grip

€ 150,00

LIFTING/HOISTING



DRS75-124 Pro Strop 26 Cable 4M

€ 235,00



DRS75-128 Pro Strop 26 Cable 8M

€ 375,00



DRS75-138 Pro Strop 34 Cable 8M

€ 718,00

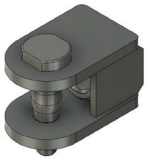

DRS90-05 Universal trailer hitch

€ 185,00

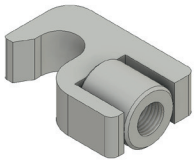

DRS90-01 Threaded hook set

€ 530,00

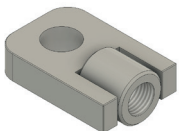

DRS90-03 Universal Winch Eye Set

€ 530,00

ACCESSORIES

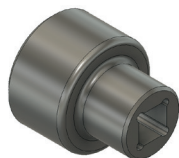

DRS62-12 Cap for Tap 12 mm - 3/4"
Scania

€ 70,00



DRS62-18 Cap for Tap 18 mm - 3/4"
Volvo

€ 70,00

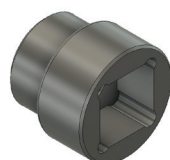

DRS62-29 Cap for Tap 29 mm - 3/4"
MAN-MB-DAF -Renault

€ 70,00



DRS62-IN17 Allen cap 17 mm 1/2"

€ 30,00



DRS62-55 Crank Hex 55mm

€ 15,00

THREAD CUTTERS

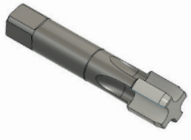

DRS20-01	M45x3.0 Mercedes-MAN-Renault
€ 130,00	



DRS20-02	M48x5.0 DAF-TATRA
€ 180,00	



DRS20-03	M45x4.5 Ford
€ 135,00	



DRS20-04	M50x2.0 Ford
€ 210,00	



DRS20-05	M33x3.5 Van Hool -VDL
€ 152,00	



DRS20-06	M30x3.5 Volvo
€ 150,00	



DRS20-07	M20x2.5 Scania
€ 32,00	

OVERVIEW

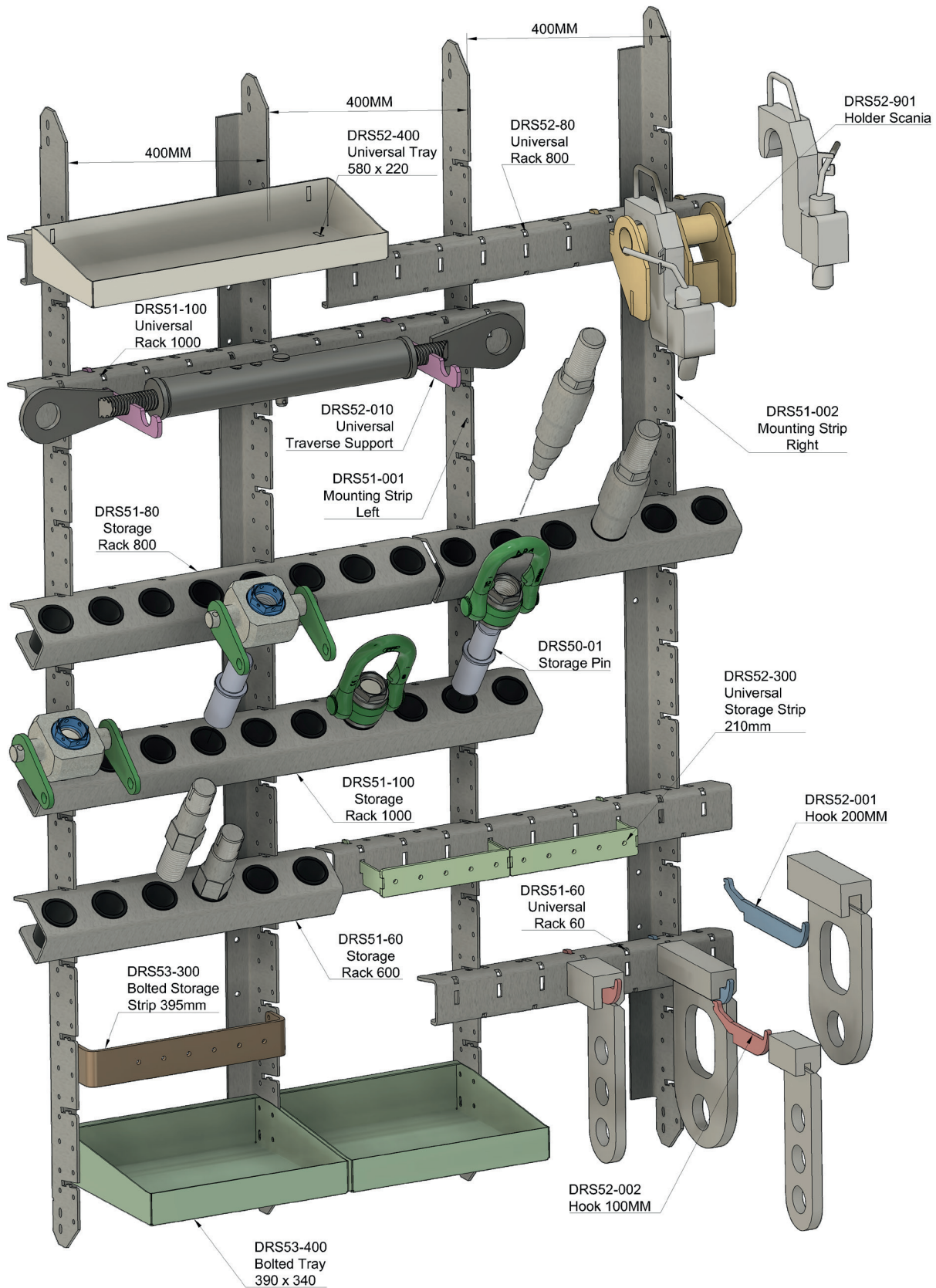

STORAGE

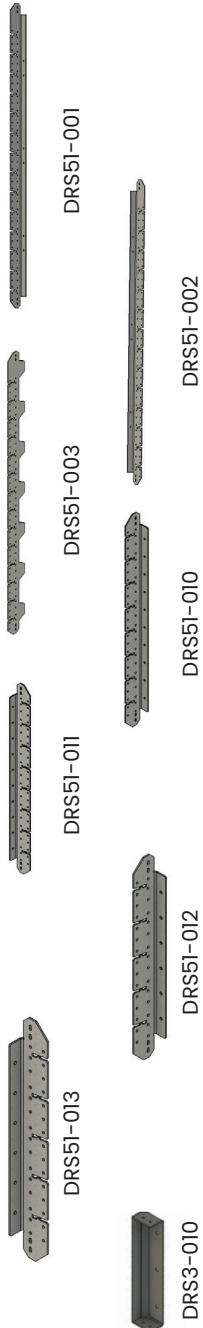

DRS51-001	Mounting strip Left Stainless Steel 2090	€ 135,00
DRS51-002	Mounting strip Right Stainless Steel 2090	€ 135,00
DRS51-003	Welded Mounting Strip of Stainless Steel 2090	€ 135,00
DRS51-010	Mounting strip Left Stainless Steel 1200	€ 89,00
DRS51-011	Mounting strip Right Stainless Steel 1200	€ 89,00
DRS51-012	Mounting strip Left Stainless Steel 800	€ 62,00
DRS51-013	Mounting strip Right Stainless Steel 800	€ 62,00
DRS3-010	Screwed Spacer 400	€ 39,00

Example application DRS3-010

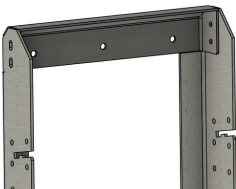

STORAGE

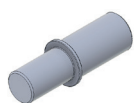
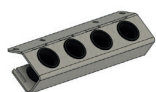

DRS51-100

Storage Rack
Stainless Steel 1000

€ 195,00

DRS51-80

Storage Rack
Stainless Steel 800

€ 185,00

DRS51-60

Storage Rack
Stainless Steel 600

€ 145,00

DRS51-40

Storage Rack
Stainless Steel 400

€ 105,00

DRS50-01

Aluminum Storage Pegs

€ 26,00

DRS51-004

Mounting strip Safety block

€ 4,05

Example application DRS51-004

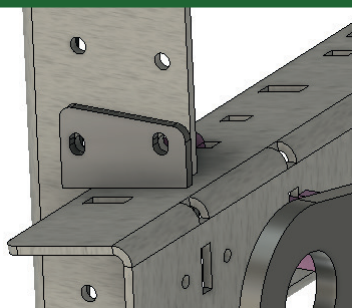

STORAGE

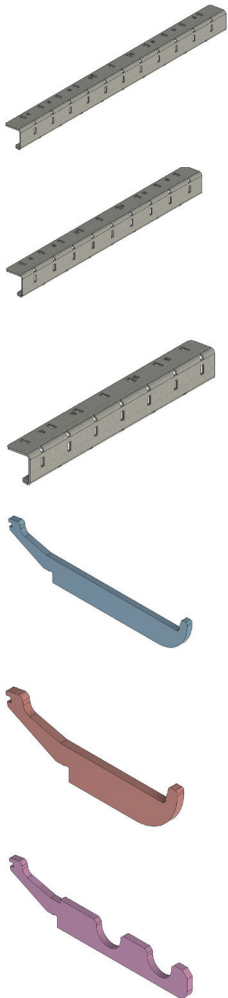

DRS52-100	Universal Rack Stainless Steel 1000	€ 92,50
DRS52-80	Universal Rack Stainless Steel 800	€ 80,00
DRS52-60	Universal Rack Stainless Steel 600	€ 70,00
DRS52-001	Universal Hook 200	€ 17,00
DRS52-002	Universal Hook 100	€ 14,00
DRS52-010	Universal Hook Traverse	€ 14,00

Example application DRS52-001 and DRS52-002

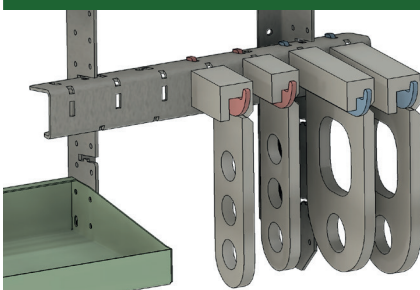

Example application DRS52-010



STORAGE

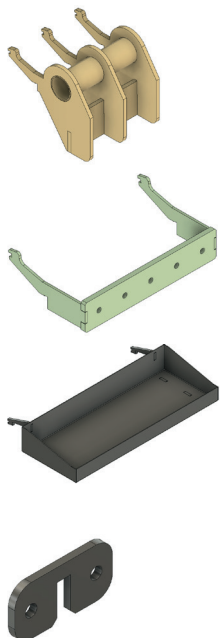

DRS52-901

Scaniaholder

€ 185,00

DRS52-300

Universal Storage Strip 210

€ 41,00

DRS52-400

Universal Tray 580 x 220

€ 105,00

DRS52-003

Universal Rack Safety Block

€ 3,80

Example application DRS52-901

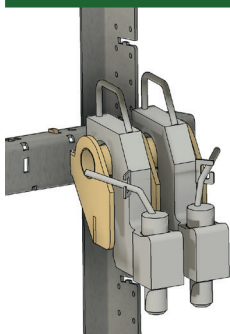

Example application DRS52-300

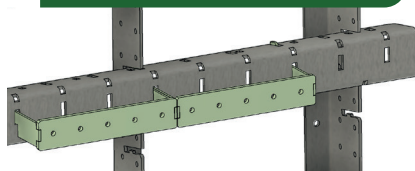

Example application DRS52-003

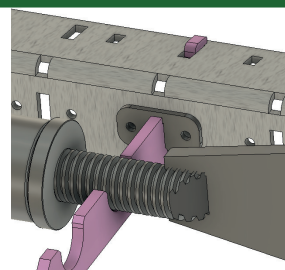

Example application DRS52-003

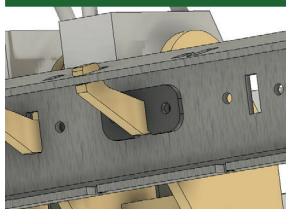

STORAGE

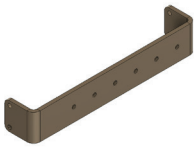

DRS53-300

Storage strip with bolts, 395

€ 46,00

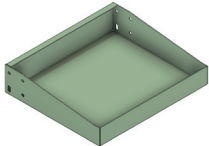

DRS53-400

Screwed Tray 390 x 340

€ 135,00

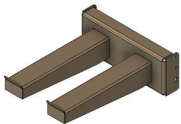

DRS53-800

Screwed Bracket Support

€ 385,00

Example application DRS53-300 and DRS53-400

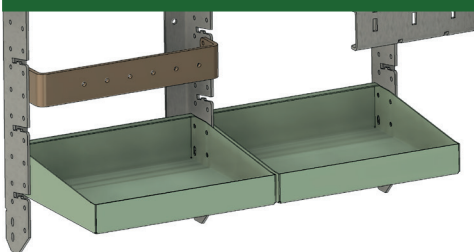

Example application DRS53-800

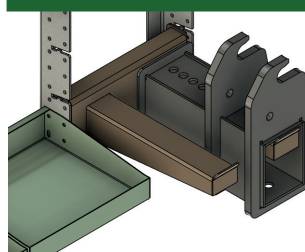



***DUTCH
RECOVERY
SYSTEM***

Dutch Recovery System B.V.
Morseweg 7
4104 BL Culemborg
Netherlands
+316 424 062 99

INNOVATIVE DAMAGE-FREE TOWING AND RECOVERY SYSTEM